

Using of Microstrip Feeding Techniques in patch Antenna

Mangilal Meghwal, M .Tech In Digital Communication

Dr. Manisha Gupta, Research Supervisor

JECRC University, Jaipur, Rajasthan, India

Abstract

In this research paper describes the performance analysis of different feeding technique for wireless Microstrip patch antenna system. This feeding technique gives a better understanding of design parameters of an antenna and their effect on return losses, bandwidth, VSWR and resonant frequency. In this, feeding technique used for enhancing bandwidth of a patch antenna is presented.

Keyword: Microstrip, Antenna, Shape, Feeding, Line, Parameter.

INTRODUCTION:

Microstrip patch antennas can be fed by a variety of methods. These methods can be classified into categories. In this technique, the power is fed directly to the radiating patch using a connecting element such as a Microstrip line. The Microstrip feeding techniques, electromagnetic field coupling is done to transfer power between the microstripline and the radiating patch antenna. The most popular contact feed techniques are

presented in this research paper with comparison to each other.

MICROSTRIP FEEDING TECHNIQUE

1. Microstrip Line Feed Technique on E Shape Patch Antenna:

To design an antenna with Microstrip Line Feed Technique a Microstrip line of dimension Length = 27 mm and width = 10 mm are used instead of probe feed technique. Figure 1 shows the simulated antenna using Microstrip feed technique.

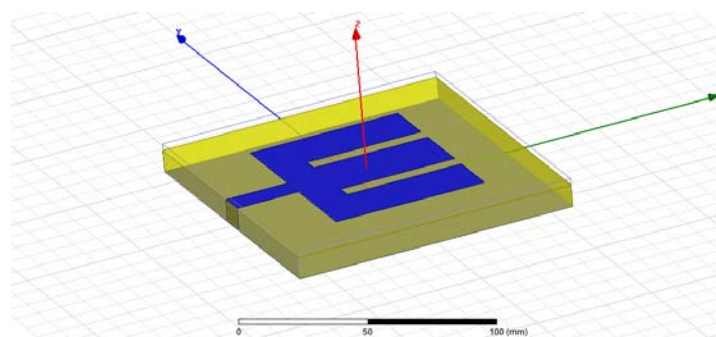

Figure 1: Microstrip Line Feed Technique on E Shape Patch Antenna

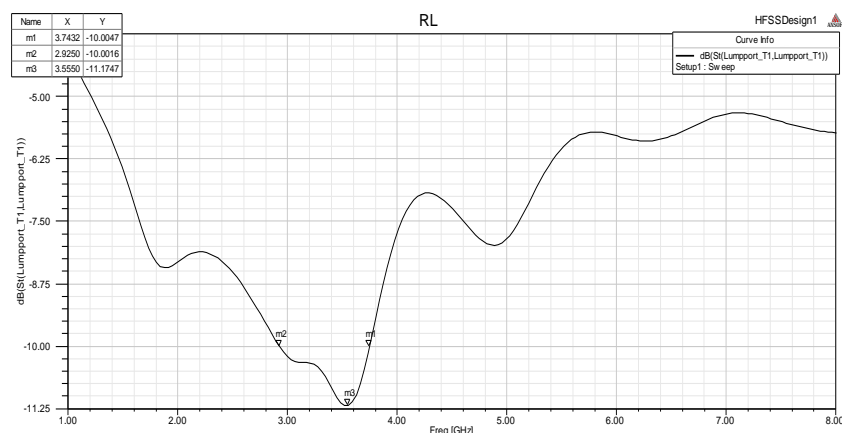

Figure 2: S11 parameter of Microstrip Line Feed Technique

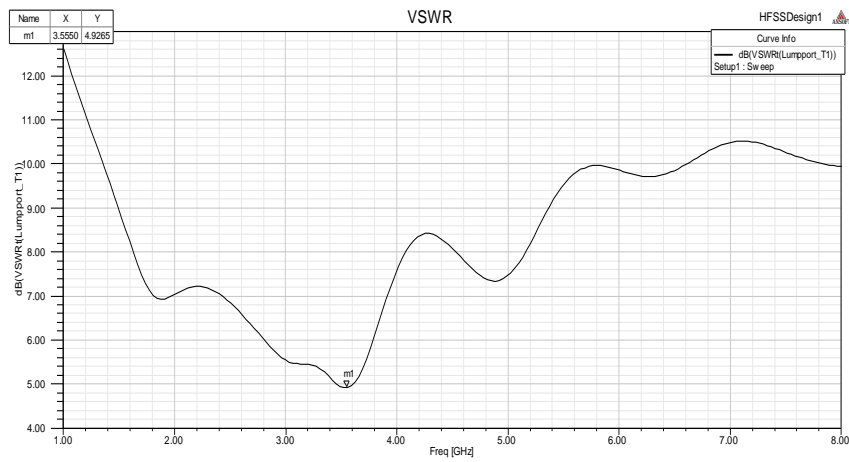

Figure 3: VSWR of Microstrip Line Feed Technique

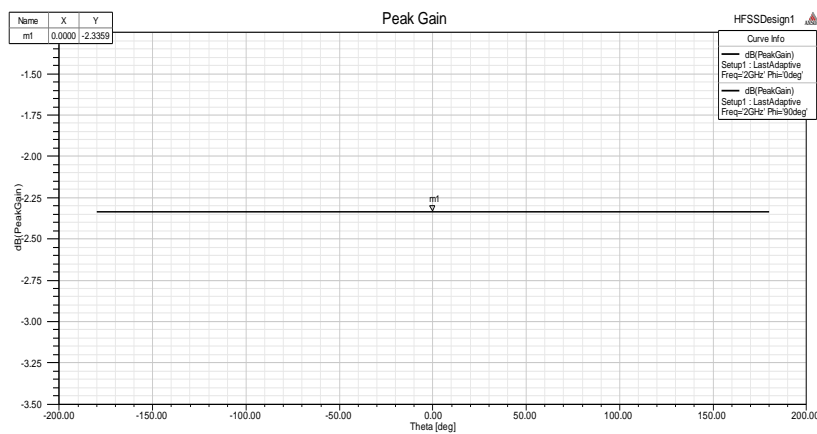

Figure 4: Peak Gain of Microstrip Line Feed Technique

Figure 2 Shows the S11 parameter of Microstrip patch antenna. We got $F_{max} = 3.74$ GHz, $F_{min} = 2.92$ GHz and we got $BW = 0.82$ GHz at resonant frequency of 3.55 GHz. Figure 3 and Figure 4 Shows the VSWR graph with $VSWR = 4.92$ dB and Gain graph i.e. -2.33 dB. So this antenna using Microstrip feed line is not efficient because of higher VSWR and negative gain.

2. Microstrip Line Inset Feed Technique on E Shape Patch Antenna

Figure 5 shows the Microstrip Line Inset Feed Technique on E Shape Patch Antenna, which gives better BW than Microstrip feed line technique. To design an antenna with Microstrip Line Inset Feed Technique a Microstrip line of dimension Length = 37 mm and width = 10 mm are used instead of probe feed technique.

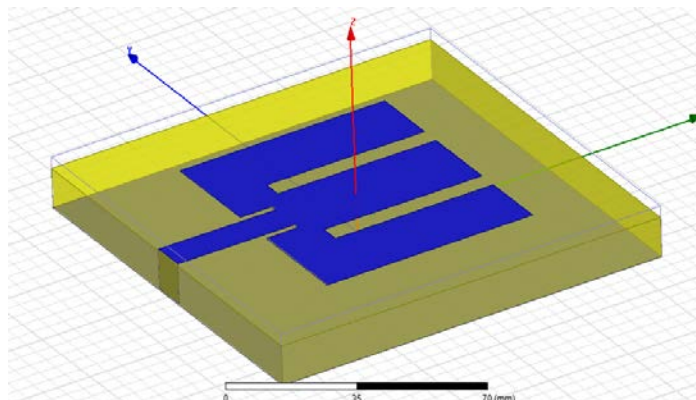

Figure 5: Microstrip Line Inset Feed Technique on E Shape Patch Antenna

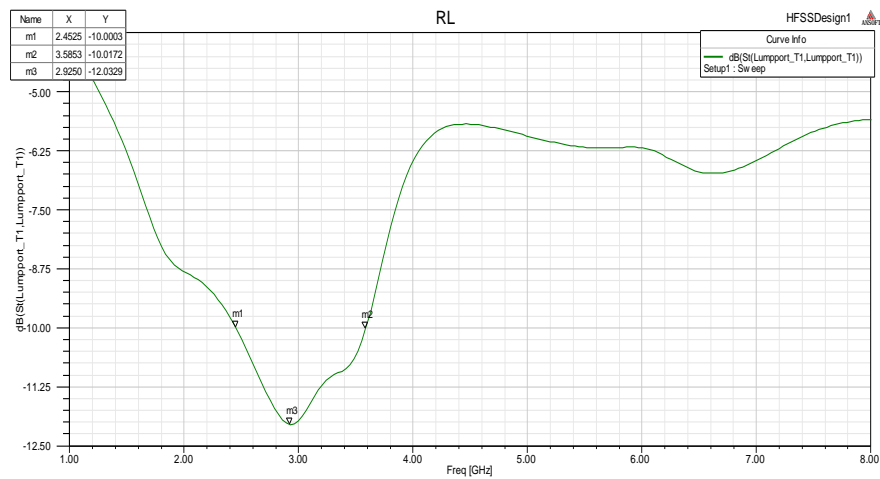

Figure 6: S11 parameter of Microstrip Line Inset Feed Technique

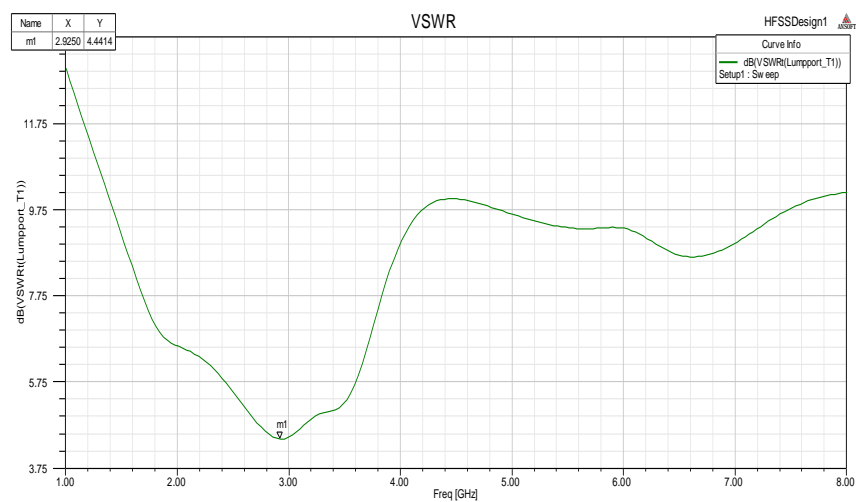

Figure 7: VSWR of Microstrip Line Inset Feed Technique

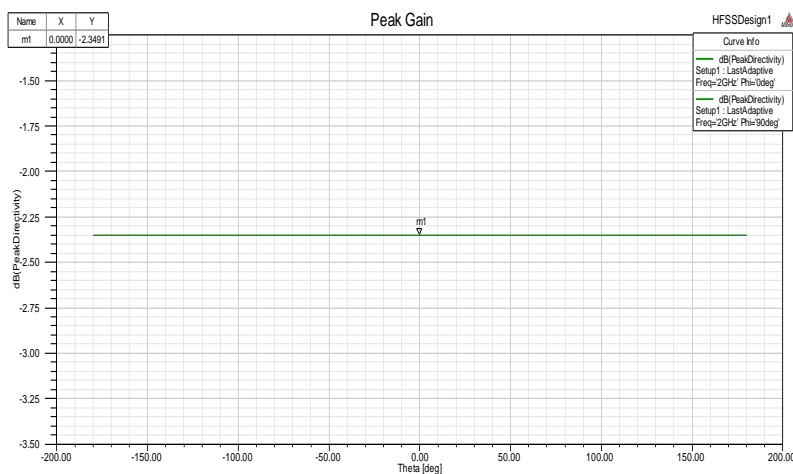

Figure 8: Gain of Microstrip Line Inset Feed Technique

Figure 6 Shows the S11 parameter of Microstrip patch antenna. We got $F_{max} = 3.75$ GHz, $F_{min} = 2.45$ GHz and we got $BW = 1.3$ GHz at resonant frequency of 2.92 GHz. Figure 7 and Figure 8 Shows the VSWR graph with VSWR

$= 4.44$ dB and Gain graph i.e. -2.97 dB. So this antenna using Microstrip feed line is not efficient because of higher VSWR and negative gain.

3. Comparison between Microstrip Line Feed, Microstrip line Inset Feed and Probe feed:

Figure 9 Shows the S11 parameter of Microstrip Line Feed, Microstrip line Inset Feed and Probe feed. We

studied three feeding techniques of feeding patch antenna and we got best result with probe feed technique.

Table 1: Comparison between Microstrip Line Feed, Microstrip line Inset Feed and Probe feed

Red Graph : Probe Feed	Green Graph : Microstrip Inset Feed	Black Graph : Microstrip Feed
1. Bandwidth=1.85GHz	2. BW=1.13 GHz	1. BW=0.82 GHz
2. VSWR= 0.97 dB at 2.5 GHz and 1.97 dB at 1.4 GHz	2. VSWR = 4.44 GHz	2. VSWR = 4.92 GHz
3. Peak Gain = 2.7 dB	4. Gain= - 2.93 dB	3. Gain= - 2.36 dB

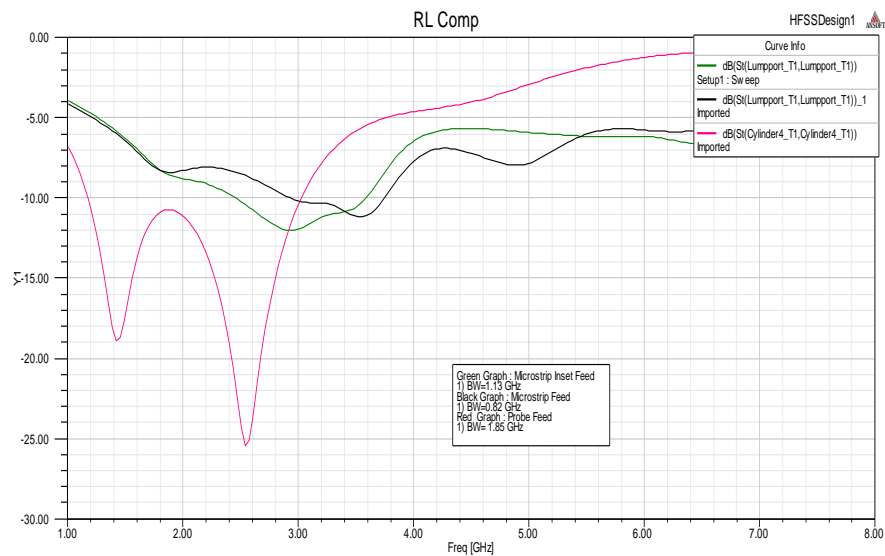

Figure 9: S11 parameter of Microstrip Line Feed, Microstrip line Inset Feed and Probe feed

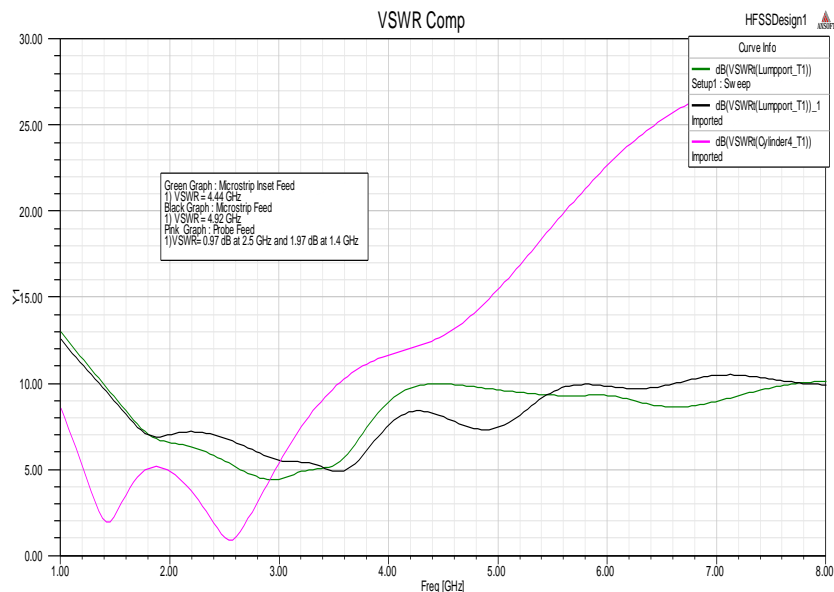

Figure 10: VSWR of Microstrip Line Feed, Microstrip line Inset Feed and Probe feed

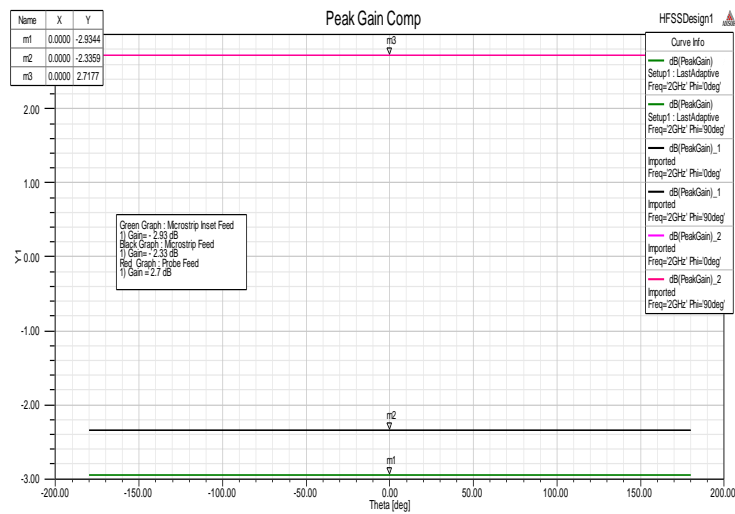

Figure 11: Gain of Microstrip Line Feed, Microstrip line Inset Feed and Probe feed

4. Two more slots are cutting on E patch:

Figure 12 shows the geometry of E shape with two more slots on the same patch. Figure 14 Shows the S11 parameter of Microstrip patch antenna. We got $F_{max} = 3.13$ GHz, $F_{min} = 1.18$ GHz and we got $BW = 1.95$ GHz at resonant frequency of 1.38 GHz and 2.61 GHz. Figure 15 and Figure 16 Shows the VSWR graph with $VSWR = 1.71$ dB at 1.38GHz and 0.84 dB at 2.6 GHz and Gain graph i.e. 2.46 dB. So this antenna is very efficient.

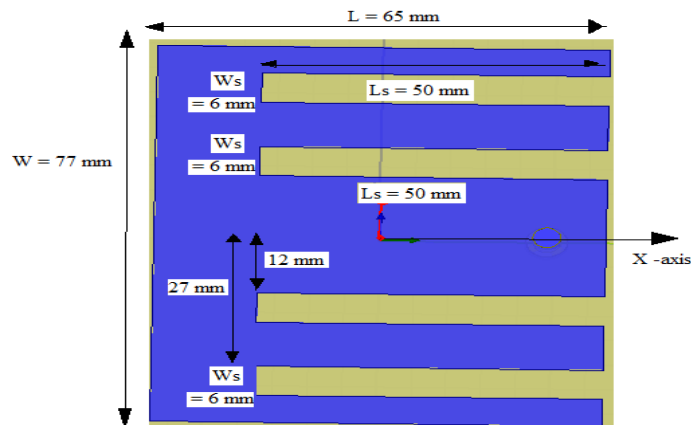

Figure 12: multiple slotted patch

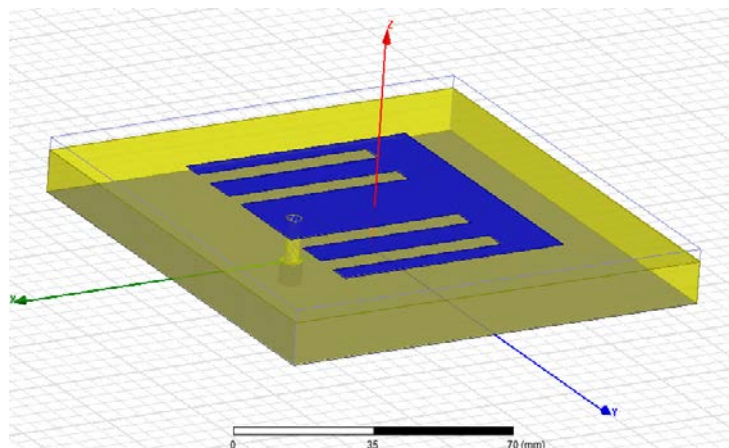

Figure 13: simulated multiple slotted patch

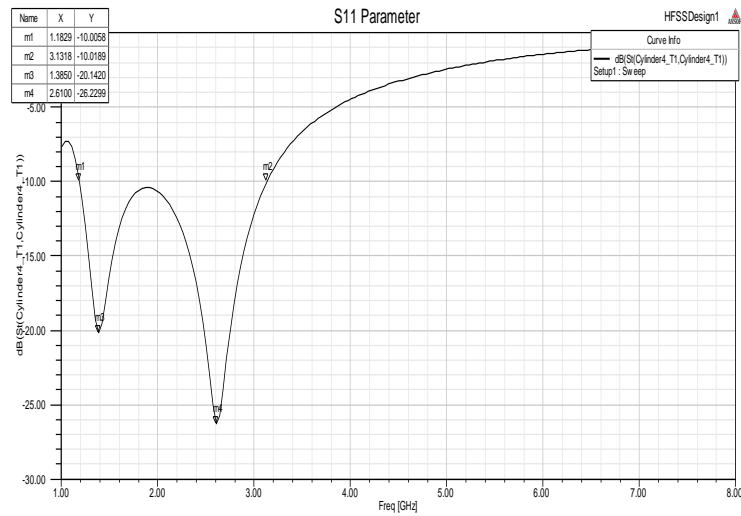

Figure 14: S11 parameter of Multiple slotted patch

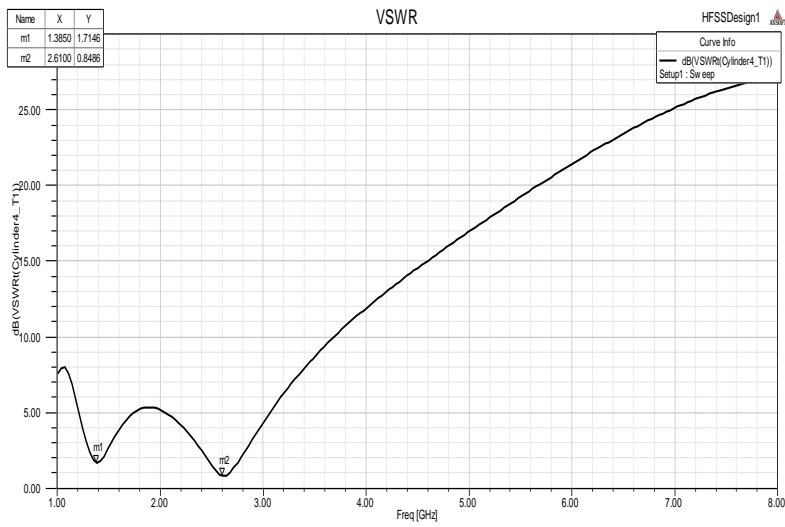

Figure 15: VSWR of Multiple slotted patch

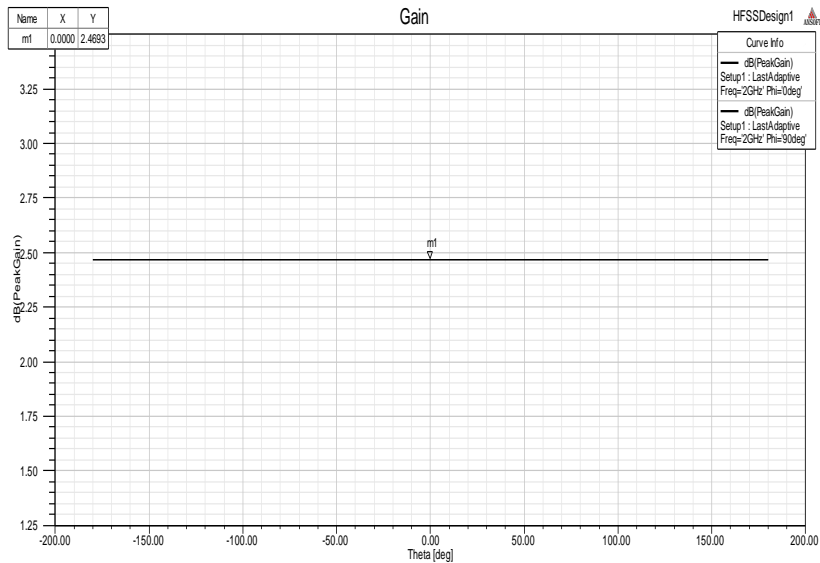

Figure 16: Peak Gain of Multiple slotted patches

5. Comparison between E shape and Multiple slotted patch antenna:

Figure 17 Shows the S11 parameter of E shape and multiple slotted patch antennas. We got best result with multiple slotted patch. BW of multiple slotted patch is 1.95 GHz whereas E shape patch has 1.85 GHz, 5.4 % BW enhancement by using multiple slotted patch. Figure 18 shows the VSWR comparison. Multiple Slotted patch has

two resonant frequencies i.e. 1.71 at 1.38GHz and 0.87 at 2.6 GHz, while E shape patch has VSWR of 0.97 dB at 2.5 GHz and 1.97 dB at 1.4 GHz.

Figure 19 shows the Peak Gain comparison. E shape has Gain = 2.7 dB and Multiple slotted patch has Gain of 2.46 dB. E shape patch have better Gain than multiple slotted patch but the difference is not so much.

Table 2: Comparison between E shape and multiple slotted patch

Black Graph = Multiple Slotted patch	Pink Graph = E shape patch
Bandwidth = 1.95GHz	Bandwidth = 1.85GHz
VSWR = 1.71 at 1.38GHz 0.87 at 2.6 GHz	VSWR = 0.97 dB at 2.5 GHz and 1.97 dB at 1.4 GHz

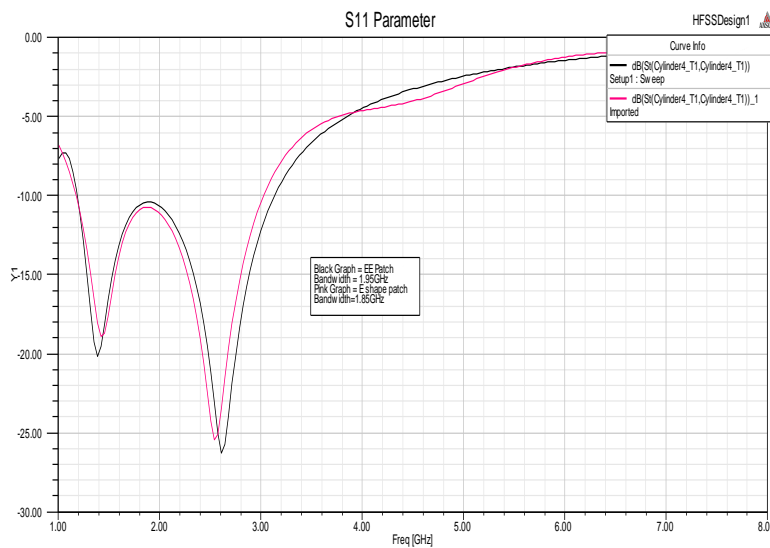

Figure 17: S11 parameter of E shape and multiple slotted patch

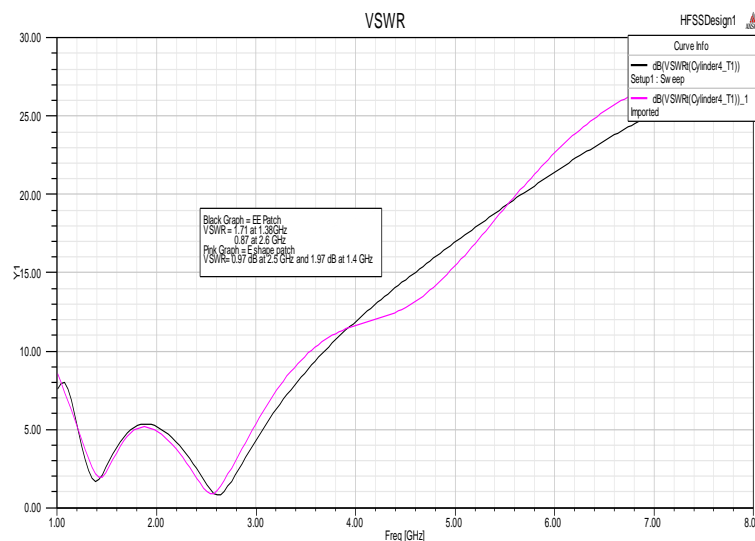

Figure 18: VSWR of E shape and multiple slotted patch

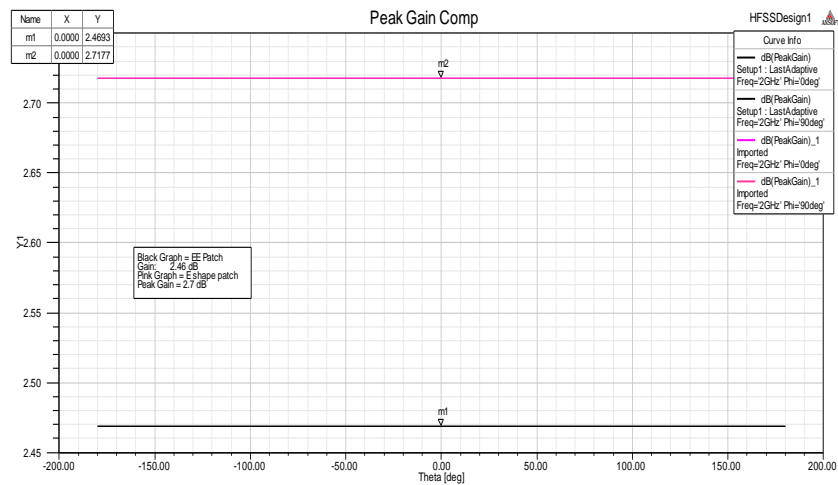

Figure 19: Gain of E shape and multiple slotted patch

6. Result and Conclusion

In this, antenna technique for enhancing bandwidth of a patch antenna is presented. Two parallel slots and multiple slots are incorporated in the rectangular Microstrip antenna such that it closely resembles an E shape. We got best result with multiple slotted patch. Bandwidth of multiple slotted patch is 1.95 GHz where as E shape patch has 1.85 GHz, 5.4% BW enhancement by using multiple slotted patch. Multiple Slotted patch has two resonant frequencies i.e. 1.71 at 1.38GHz and 0.87 at 2.6 GHz, while E shape patch has VSWR of 0.97 dB at 2.5 GHz and 1.97 dB at 1.4 GHz. E shape has Gain = 2.7 dB and Multiple slotted patch has Gain of 2.46 dB. E shape patch have better Gain than multiple slotted patch but the difference is not so much.

The design of the antenna has two parallel slots incorporated in it and thick air foam to enhance bandwidth as well as gain of the signal, as a result of which the radiation pattern degrades. The designed antenna was fabricated on the RT 3003 substrate with air foam sandwiched between the ground plane and the patch; also it has been fabricated conveniently due to its simple structure. The developed antenna was successfully tested at the anechoic chamber. The measured and the simulation result are been so far in good agreement.

7. Reference

1. B.T Abdul Ghafar Nurulrodziah, "Design of a Compact Microstrip Antenna at 2.4 GHz", MSc thesis, Department of Electrical – Electronics & Telecommunications, Universiti Teknologi, Malaysia, (2005).
2. K. C. Gupta and A. B. Norwood, "Microstrip Antenna Design". Norwood, MA Artech House, (1988).
3. K. L. Virga and Y. Rahmat-Samii, "Low profile enhanced-bandwidth IFA antennas for wireless communications packaging," IEEE Trans. Microwave Theory Tech., 45, 1879–1888 (1997).
4. B. L. Ooi and Q. Shen, "A novel E-shaped broadband microstrip patch antenna," Microw. Opt. Technol. Lett., 27(5), 348–352 (2000).
5. C.A. Balanis, "Antenna Theory Antenna Analysis & Design", John Wiley & Sons, 2nd edition, (1993).
6. D.M. Pozar, "Microstrip Antennas", Proc. IEEE, 80, 79-91 (1992).
7. G. Yuehe ,P. Karu P. and S. Trevor "A Compact E-Shaped Patch Antenna With Corrugated Wings", IEEE transaction on antennas and propagation, 54(8), (2006).
8. K. L Wong and W.H Hsu. "A broad-band rectangular patch antenna with a pair wide slits".IEEE Trans. Antennas Propagat., 49(9),1345-1347 (2001).
9. T. Huynh, K. F. Lee, and R. Q. Lee. "Cross Polarization Characteristic Rectangular Patch Antennas". Electron. Lett., 24, 463-464 (1998).
10. A.G Derneryd and I. Karlson, "Broadband Microstrip Antenna Element and Array", IEEE Trans. Antennas Propagat., 24, 140- 1141 (1981).
11. S. Maci, G. Biffi-Gentilli, P. Piazzesi, and C.Salvador, "Dual-band slot-loaded patch antenna," IEEE Proc.-Microw. Antennas Propag.,142,(3), 225-232 (1995).
12. M. Olyphant and T.E Nowicki, "Microwave substrates support MIC technology" Microwaves, Part I, 19(12), 74-80 (1980).
13. D. Yadav, L-Slotted rectangular microstrip patch antenna International conference on communication systems and network technologies, (2011).

14. B. Vedaprabhu. and K.J. Vinoy, "A double U-Slot patch antenna with dual wideband characteristics", IEEE, (2010).
15. S.D. Gupta ,A. Singh , "Design of Microstrip Planar Antenna Array and Study of Effect on Antenna Parameters due to Mutual Coupling in both E and H Planes", International Journal of Communication Engineering Applications (IJCEA), 02(06).(2011).
16. I. Dafalla, W. T. Y. Kuan, A. M. Abdel Rahman, and S. C. Sudhakar, "Design of rectangular Microstrip patch antenna at 1GHz", Multimedia University, Faculty of engineering and technology, Melaka, Malaysia. "RF and Microwave Conference,". Malaysia. (2004).